

3-100L/SL



Carriers

1 - 2 ton Loaders

Weight

360kgs

Capacity

0.23m³

Flow

65 lpm

Screening Area

430mm x 1000mm

Dimensions

A - 430mm D - 1210mm

B - 1000mm E - 760mm

C - 530mm F - 710mm

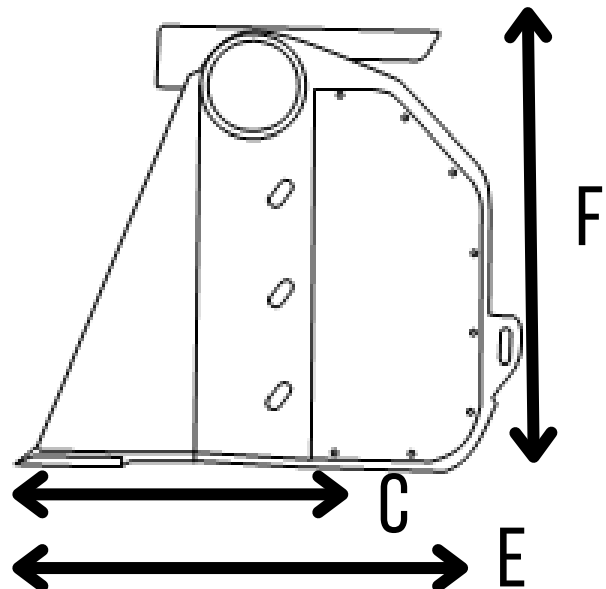
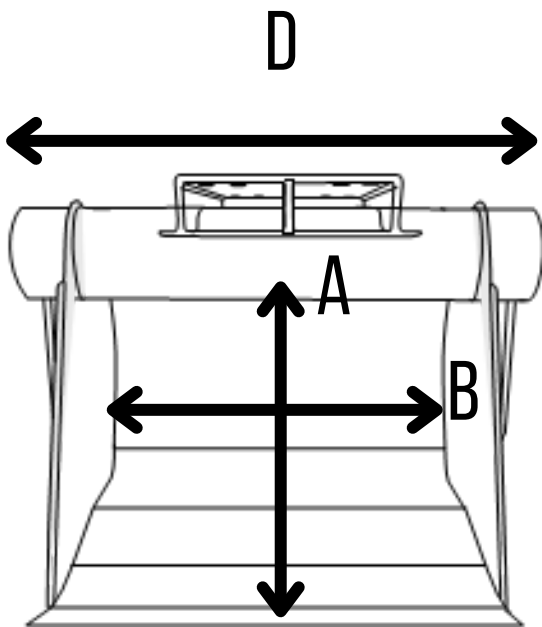

True Compact Screening
Low maintenance System
Poly-Stars screen without crushing
Non-stick floor as standard